

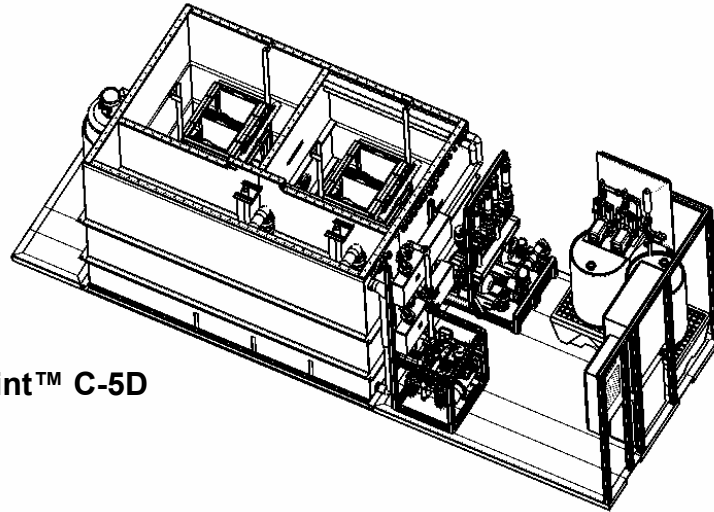

## Seapoint C-5D Specification

### Containerized Wastewater Treatment Package Plant



Seapoint™ C-5D

#### **Wastewater Processing Capabilities:**

- Treatment system based on flat-plate membrane bio-reactor (MBR) technology
- Up to 4.3 GPM, 6,250 GPD average flow
- Up to 8.7 GPM, 12,500 GPD emergency flow (up to 24 hours)
- Effluent *Supplied Head Pressure*: 15' minimum

**Influent, Effluent, and Process Characterization:** The following influent and effluent values are for standard plant equipment. Additional treatment options are available for influent concentrations that exceed these values and effluent concentrations that must be lower.

#### • **Wastewater Influent**

- *Maximum Particle Size*: 1/8" (3 mm)
- *TSS*: 30-day average not to exceed 300 mg/L
- *BOD<sub>5</sub>*: 30-day average not to exceed 300 mg/L
- *TKN*: 30-day average not to exceed 45 mg/L

#### • **Process Conditions**

- *Operating Temperature*:
  - For 6,250 GPD: 59°F (15°C) to 80°F (27°C)
  - For 5,000 GPD: 50°F (10°C) to 80°F (27°C)
- *MLSS Concentration*: 12,000 mg/L (typical)
- *pH*: 5.0 – 9.0

#### • **Treated Effluent**

- *TSS*: 30-day average not to exceed 5 mg/L
- *BOD<sub>5</sub>*: 30-day average not to exceed 5 mg/L
- *Total Nitrogen*: 30-day average not to exceed 10 mg/L
- *Turbidity*: 30-day average not to exceed 1.0 NTU
- *Fecal Coliform Bacteria*: None detectible

# Seapoint C-5D Specification

## Materials of Construction:

- All treatment tanks and equipment are installed in a 20" ISO shipping container
- Tanks are a fabricated, welded steel unit
- Mounting hardware for equipment inside the tanks is stainless steel
- Tanks are protected with an epoxy paint
- Container is fully insulated

## Mechanical Equipment:

- Effluent pumps, recirculation pumps, aeration blowers, control valves, and ultraviolet disinfection units are pre-mounted on the C-5D
- Supply pumps are included with the C-5D for installation in the equalization tank
- Standard system has installed backups for pumps, blowers, and UV disinfection
- An odor control system treats the process air released from the MBR

## Electric Power Requirements:

- *Customer Supplied Inlet Power:* 3 phase power standard. Single-phase option available.
- *Voltage and Frequency:* will match local requirements
- *Frequency Stability Limit:* +/- 1 Hz of specified line frequency
- *Line Voltage Fluctuation Limit:* +/- 5%
- *Power:*
  - Average Operating: 9 kW
  - Peak Operating: 14 kW
  - Connected Equipment: 24 kW

Note: Estimated power usage is based on pump and blower ratings. Actual power usage depends on operating conditions and will normally be lower.

## Plumbing Connections (at the C-5D interface):

- *Wastewater Influent:* a 1 ½" PVC connection for inflow from the equalization tank
- *Treated Effluent:* a 1" PVC connection for permeate discharge
- *Sludge Wasting:* a 1 ½" PVC connection for wasting sludge to either a holding tank or to a tank truck
- *Drain:* a 2" PVC connection to drain MBR tanks to equalization tank

## System Controls & Process Monitoring:

- Control system based on a GE Fanuc PLC
- Display panel for alarms and faults
- System designed for total automatic operation including automatic switchover to standby equipment if required
- Optional automatic telephone dialer for emergency notification

# Seapoint C-5D Specification

## Environmental Conditions:

- *Operating Temperature:* ambient temperatures ranging from 40°F (4°C) to 90°F (32°C)
- *Seasonal Usage:* when drained, system is designed for long-term non-use (24 months or greater) with a temperature range from 140°F (60°C) to -40°F (-40°C)

## System Size and Weight:

- Empty Weight (without water) = 13,000 pounds (6,000 kg)
- Operating Weight (with water) = 30,000 pounds (14,000 kg)
- Size: 20' long, 8' wide, and 8' high  
(610 cm long, 245 cm wide, and 245 cm high)  
Notes: Height does not include allowance for a removable tank cover for foam and odor containment (add approximately 24" to height)

## Site Preparation Requirements:

- **Location:** The installation site should be located in close proximity to the wastewater collection area and a power source sufficient to operate the system. The installation must permit access by equipment capable of transporting, offloading, and handling the design loads.
- **Site Suitability:** The site must be level and stable enough to support the system gross weight, when fully loaded and processing wastewater.
- **Additional Tanks:** A collection/separation tank, which receives all wastewater, and an equalization tank, which supplies the treatment unit, are required. The minimum size of each is determined in consultation with SEAPOINT after evaluation of the application's flow distributions and collection system design. A sludge holding tank is optional. Its need is depends on how the owner decides to operate and maintain the system. Tanks are available from SEAPOINT as options.
- **Filtering:** Filters capable of removing all particles greater than 1/8 inch are required. Static filters for installation between the collection and equalization tanks are supplied with the unit. An optional bar screen for installation between the equalization tank and treatment plant is available.
- **Site Work:** Installation of enclosure, pallets, and tanks, and all on-site plumbing, electrical, and mechanical connections are the responsibility of the customer.

**Seapoint™ Package Plants**  
**Seapoint, LLC**  
[www.seapointllc.com](http://www.seapointllc.com)  
**Phone: (978) 887-3552**